

The University of the State of New York
REGENTS HIGH SCHOOL EXAMINATION

**PHYSICAL SETTING
EARTH SCIENCE**

Friday, June 14, 2013 — 9:15 a.m. to 12:15 p.m., only

The possession or use of any communications device is strictly prohibited when taking this examination. If you have or use any communications device, no matter how briefly, your examination will be invalidated and no score will be calculated for you.

Use your knowledge of Earth science to answer all questions in this examination. Before you begin this examination, you must be provided with the *2011 Edition Reference Tables for Physical Setting/Earth Science*. You will need these reference tables to answer some of the questions.

You are to answer all questions in all parts of this examination. You may use scrap paper to work out the answers to the questions, but be sure to record your answers on your answer sheet and in your answer booklet. A separate answer sheet for Part A and Part B–1 has been provided to you. Follow the instructions from the proctor for completing the student information on your answer sheet. Record your answers to the Part A and Part B–1 multiple-choice questions on this separate answer sheet. Record your answers for the questions in Part B–2 and Part C in your separate answer booklet. Be sure to fill in the heading on the front of your answer booklet.

All answers in your answer booklet should be written in pen, except for graphs and drawings, which should be done in pencil.

When you have completed the examination, you must sign the declaration printed on your separate answer sheet, indicating that you had no unlawful knowledge of the questions or answers prior to the examination and that you have neither given nor received assistance in answering any of the questions during the examination. Your answer sheet and answer booklet cannot be accepted if you fail to sign this declaration.

Notice . . .

A four-function or scientific calculator and a copy of the *2011 Edition Reference Tables for Physical Setting/Earth Science* must be available for you to use while taking this examination.

DO NOT OPEN THIS EXAMINATION BOOKLET UNTIL THE SIGNAL IS GIVEN.

Part A

Answer all questions in this part.

Directions (1–35): For *each* statement or question, choose the word or expression that, of those given, best completes the statement or answers the question. Some questions may require the use of the *2011 Edition Reference Tables for Physical Setting/Earth Science*. Record your answers on your separate answer sheet.

1 The terrestrial planets differ from the Jovian planets because the terrestrial planets are

- (1) less dense and larger
- (2) less dense and smaller
- (3) more dense and larger
- (4) more dense and smaller

2 Energy is produced within a star's core by the process of

- (1) insolation
- (2) conduction
- (3) nuclear fusion
- (4) radioactive decay

3 The graph below shows the tidal changes in ocean water level, in meters, recorded at a coastal location on a certain day.

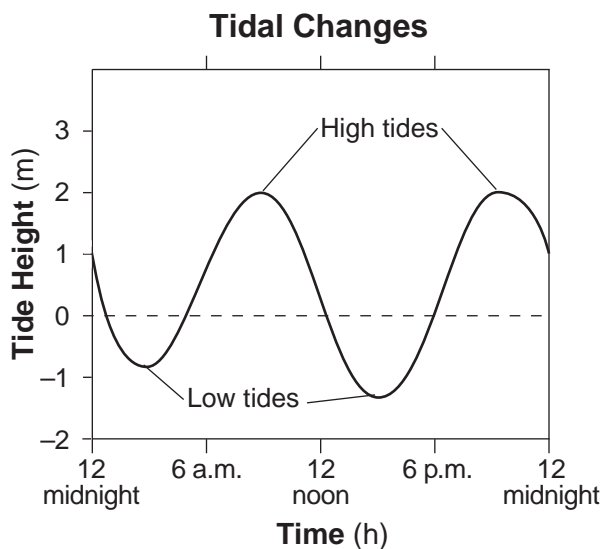

Approximately how many hours apart were the two high tides?

- (1) 6 h
- (2) 12 h
- (3) 18 h
- (4) 24 h

4 Ocean tides observed at coastal locations each day are primarily caused by

- (1) Earth's revolution around the Sun
- (2) the changing phases of the Moon
- (3) the gravitational attraction between the Moon and Earth
- (4) seasonal changes in the compass location of sunrise

5 If Earth's rate of rotation increases, the length of one Earth day will be

- (1) shorter than 24 hours
- (2) longer than 24 hours
- (3) 24 hours, with a shorter nighttime period
- (4) 24 hours, with a longer nighttime period

6 Which hot spot location on Earth's surface usually receives the greatest intensity of insolation on June 21?

- (1) Iceland
- (2) Hawaii
- (3) Easter Island
- (4) Yellowstone

7 Compared to the luminosity and surface temperature of red main sequence stars, blue supergiants are

- (1) less luminous and have a lower surface temperature
- (2) less luminous and have a higher surface temperature
- (3) more luminous and have a lower surface temperature
- (4) more luminous and have a higher surface temperature

8 The station model below shows several weather variables recorded at a particular location.

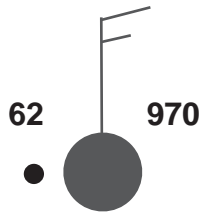

What was the most likely dewpoint at this location?

- (1) 32°F
- (2) 40°F
- (3) 61°F
- (4) 70°F

9 Which ocean current warms the climate of northwestern Europe?



- (1) North Atlantic Current
- (2) Canary Current
- (3) North Equatorial Current
- (4) Labrador Current

10 What is the usual surface wind pattern within a Northern Hemisphere low-pressure system?



- (1) clockwise and outward
- (2) clockwise and inward
- (3) counterclockwise and outward
- (4) counterclockwise and inward

11 The diagram below represents Earth in space on the first day of a season.

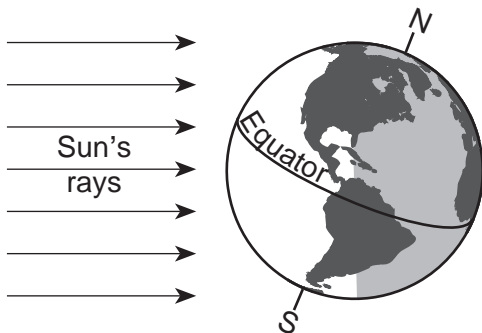

Which season is beginning in New York State on the day represented in the diagram?

- (1) winter
- (2) spring
- (3) summer
- (4) fall

12 Monsoons develop as a result of



- (1) large changes between the temperatures of a continent and neighboring oceans
- (2) a continent and neighboring oceans having nearly the same temperatures
- (3) air rising over Earth's equatorial region
- (4) air sinking over Earth's polar regions

13 At what approximate altitude in the atmosphere can stratospheric ozone be found?



- (1) 10 km
- (2) 30 km
- (3) 70 km
- (4) 100 km

14 What percentage of Earth's history represents human existence?



- (1) less than 1.0%
- (2) 1.8%
- (3) 23.5%
- (4) more than 98.6%

15 During which period in geologic history did the uplifting of the Adirondack Mountains begin?



- (1) Quaternary
- (2) Cretaceous
- (3) Triassic
- (4) Cambrian

16 Which New York State location has surface bedrock that has been subjected to very intense regional metamorphism?



- (1) 41°00' N 72°15' W
- (2) 42°30' N 75°00' W
- (3) 44°00' N 76°00' W
- (4) 44°30' N 74°00' W

17 The cross sections below represent three widely separated bedrock outcrops labeled A, B, and C. Letters W, X, Y, and Z represent fossils found in the rock layers.

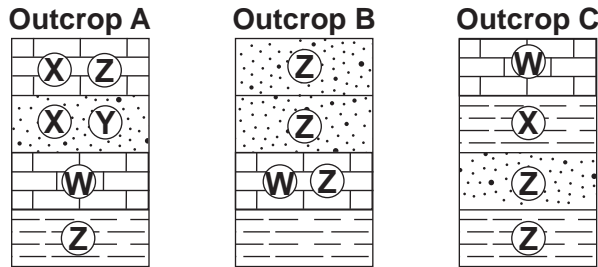

Which fossil could best be used as an index fossil?

- (1) W
- (2) X
- (3) Y
- (4) Z

18 Which scientific principle states that younger rock layers are generally deposited on top of older rock layers?



- (1) superposition
- (2) evolution
- (3) original horizontality
- (4) inclusion

19 The graph below shows the hardness of four minerals.

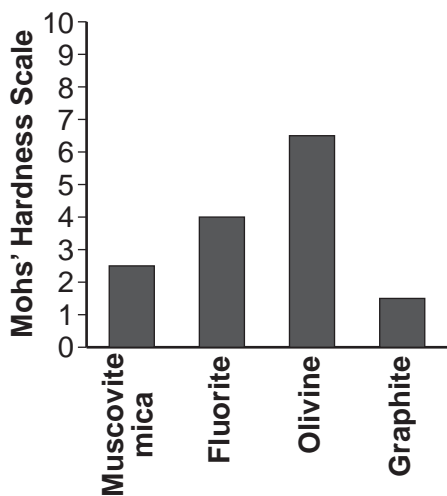

Which mineral is hard enough to scratch calcite but is *not* hard enough to scratch amphibole?

- (1) muscovite mica
- (2) fluorite
- (3) olivine
- (4) graphite

20 Earth's internal heat is the primary source of energy that



- (1) warms the lower troposphere
- (2) melts glacial ice at lower altitudes
- (3) moves the lithospheric plates
- (4) pollutes deep groundwater with radioactivity

21 The cross section of Earth below represents a P-wave moving away from an earthquake epicenter. Seismic station A is shown on Earth's surface.

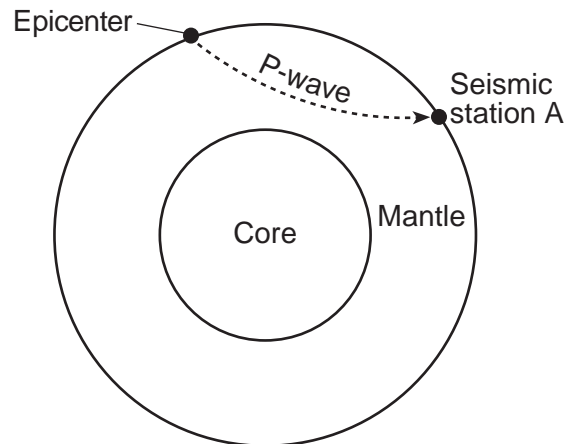

At station A, the first P-wave arrives 11 minutes 40 seconds after the earthquake. How long after the first P-wave arrives will the first S-wave arrive?

- (1) 5 minutes 00 second
- (2) 8 minutes 40 seconds
- (3) 9 minutes 40 seconds
- (4) 21 minutes 20 seconds

22 The Aleutian Islands extend westward from southern Alaska to form the northern boundary of the Pacific Ocean. These volcanic islands were formed by the nearby



- (1) subduction of a continental plate
- (2) subduction of an oceanic plate
- (3) divergence of a continental plate
- (4) divergence of an oceanic plate

23 Landscapes characterized by gentle slopes and meandering streams are most often found in regions with

- (1) steep mountain cliffs
- (2) sediment-covered bedrock
- (3) recently active faults and folds
- (4) high volcanic activity

24 The photograph below shows a valley.



Which agent of erosion most likely produced this valley's shape?

- (1) blowing wind
- (2) ocean waves
- (3) moving ice
- (4) running water

25 Pieces of bedrock material that are broken from a cliff and deposited by a landslide at the base of the cliff are best described as

- (1) rounded and sorted
- (2) rounded and unsorted
- (3) angular and sorted
- (4) angular and unsorted

26 Sandstone, limestone, and conglomerate cobbles are found in a streambed in New York State where the surrounding bedrock is composed of shales and siltstones. The most likely explanation for the presence of these cobbles is that they were

- (1) weathered from the surrounding bedrock
- (2) formed when shale and siltstone bedrock were eroded
- (3) transported to this area from another region
- (4) metamorphosed from shale and siltstone

27 The narrow, sandy, barrier islands in the ocean along the south coast of Long Island were deposited by

- (1) wind
- (2) streams
- (3) glacial ice
- (4) wave action

Base your answers to questions 28 and 29 on the data table below and on your knowledge of Earth science. The data table shows some constellations that can be seen by an observer in New York State during different seasons.

Season	Constellations
spring	Ursa Minor, Orion, Leo, Scorpius
summer	Ursa Minor, Leo, Scorpius, Aquarius
fall	Ursa Minor, Orion, Scorpius, Aquarius
winter	Ursa Minor, Orion, Leo, Aquarius

28 Which statement best explains why some constellations are *not* seen during all four seasons?

- (1) Earth revolves around the Sun.
- (2) Constellations revolve around the Sun.
- (3) The Moon revolves around Earth.
- (4) The Sun revolves around the center of the Milky Way.

29 The diagram below represents a portion of the constellation Ursa Minor. The star *Polaris* is identified.



Ursa Minor can be seen by an observer in New York State during all four seasons because Ursa Minor is located almost directly

- (1) above Earth's equator
- (2) above Earth's North Pole
- (3) overhead in New York State
- (4) between Earth and the center of the Milky Way

30 Which map shows normal paths followed by low-pressure storm centers as they pass across the United States?

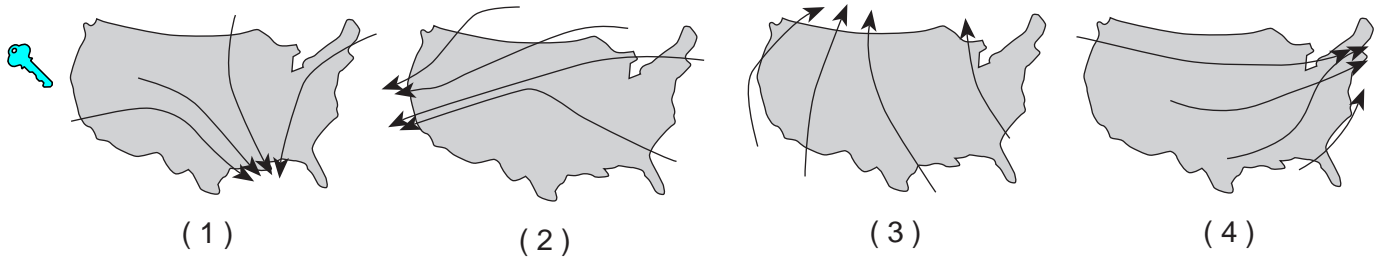

31 The diagram below represents the wet-bulb and dry-bulb temperatures on a sling psychrometer.

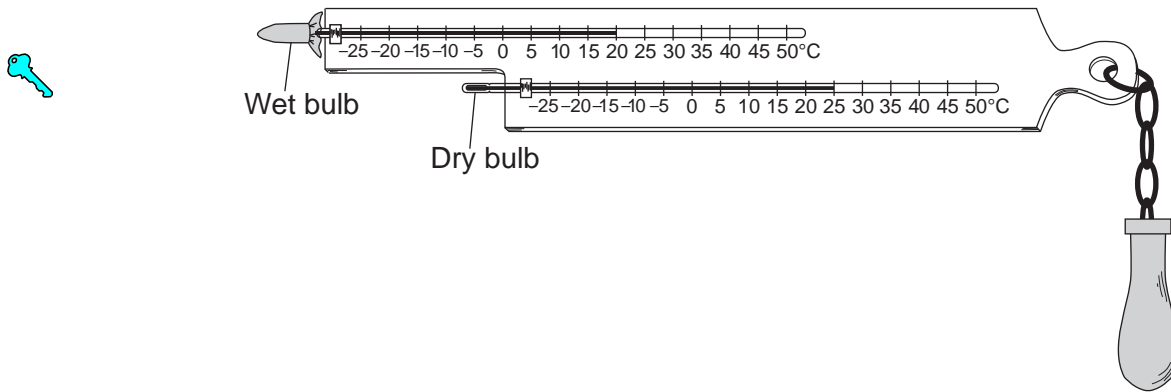

What was the relative humidity of the air when these temperatures were recorded?

- (1) 5%
- (2) 17%
- (3) 20%
- (4) 63%

32 Which set of instruments is correctly paired with the weather variables that they measure?

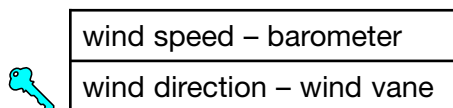

(1)

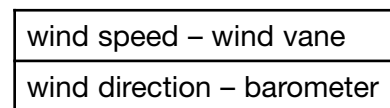

(3)

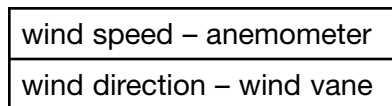

(2)

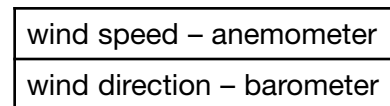

(4)

33 The map below shows four locations, *A*, *B*, *C*, and *D*, on the continent of South America.

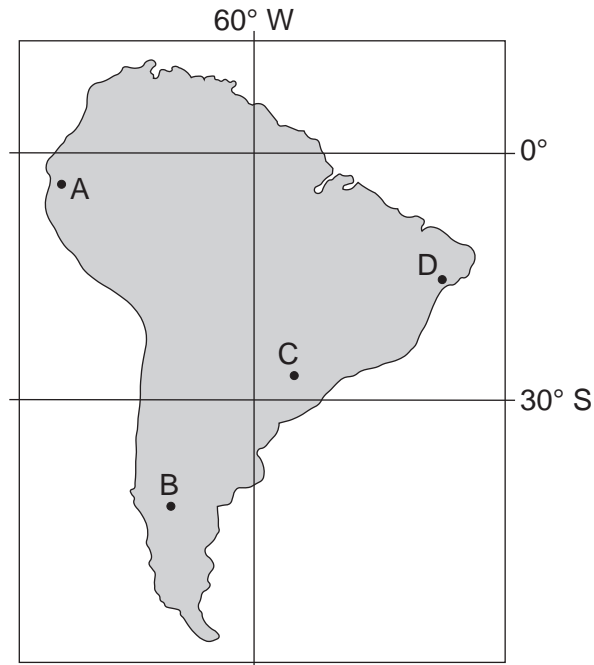

Which location is the first to experience sunset on September 23?

- (1) *A*
- (2) *B*
- (3) *C*
- (4) *D*

34 The data table below lists characteristics of rocks *A*, *B*, *C*, and *D*.



Rock Characteristics

Rock	Texture	Grain Size	Mineral Composition
A	nonfoliated	fine to coarse	calcite, dolomite, carbon
B	banding	coarse	biotite, quartz, plagioclase feldspar
C	bioclastic	microscopic to coarse	carbon, pyroxene, mica
D	foliated	fine to medium	quartz, amphibole, garnet

Which rock is most likely phyllite?

- (1) *A*
- (2) *B*
- (3) *C*
- (4) *D*

35 The cross section below represents a pattern of magnetic field reversals preserved in the igneous bedrock of the oceanic crust east of the Mid-Atlantic ridge.

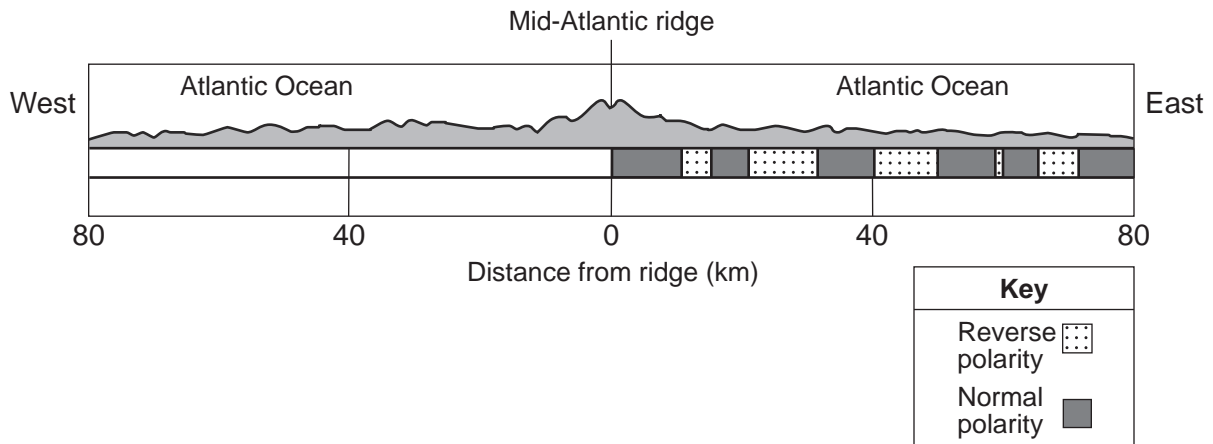

Which cross section best represents the magnetic field pattern west of the Mid-Atlantic ridge?

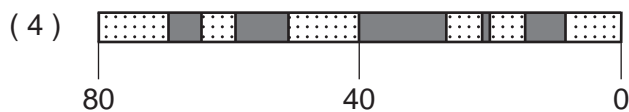
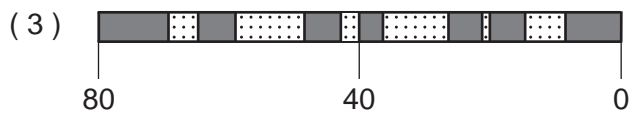
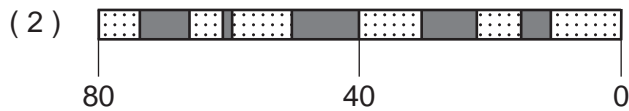
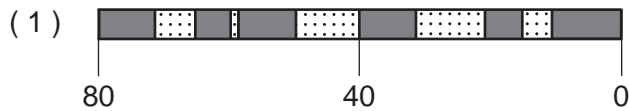

Part B-1

Answer all questions in this part.

Directions (36–50): For each statement or question, choose the word or expression that, of those given, best completes the statement or answers the question. Some questions may require the use of the 2011 Edition Reference Tables for Physical Setting/Earth Science. Record your answers on your separate answer sheet.

Base your answers to questions 36 through 38 on the weather map below and on your knowledge of Earth science. The map shows a low-pressure system with two fronts extending from its center (L). Points A, B, C, and D represent locations on Earth's surface. Two different air masses are labeled.

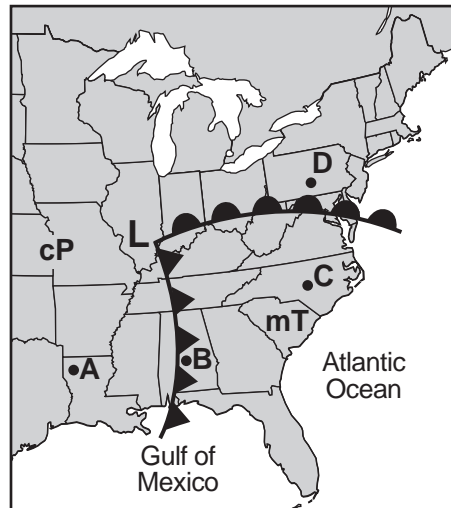

36 Which atmospheric conditions describe the air mass that is influencing weather conditions at location C?

- (1) cool and dry
- (2) cool and moist
- (3) warm and dry
- (4) warm and moist



37 Which locations are most likely experiencing precipitation?

- (1) A and B
- (2) B and C
- (3) C and D
- (4) D and B



38 Which cross section best represents the frontal boundary (fb) and general pattern of air movements between locations C and D?

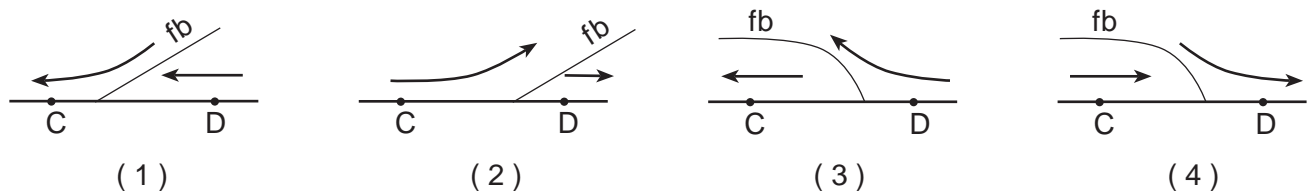

Base your answers to questions 39 through 43 on the passage below and on your knowledge of Earth science.

Cosmic Microwave Background Radiation

In the 1920s, Edwin Hubble's discovery of a pattern in the red shift of light from galaxies moving away from Earth led to the theory of an expanding universe. This expansion implies that the universe was smaller, denser, and hotter in the past. In the 1940s, scientists predicted that heat (identified as cosmic microwave background radiation) left over from the Big Bang would fill the universe. In the 1960s, satellite probes found that cosmic microwave background radiation fills the universe uniformly in every direction, and indicated a temperature of about 3 kelvins (K). This radiation has been cooling as the universe has been expanding.

39 Scientists infer that the universe began approximately

- (1) 1.0 billion years ago
- (2) 3.3 billion years ago
- (3) 8.2 billion years ago
- (4) 13.7 billion years ago



40 Which graph best shows the relationship of the size of the universe to the temperature indicated by the cosmic microwave background radiation?

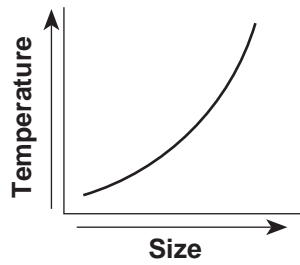

(1)

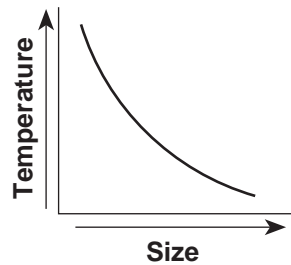

(2)

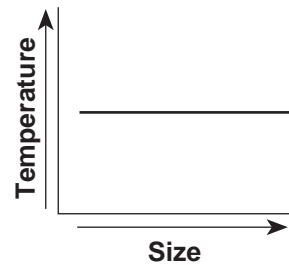

(3)

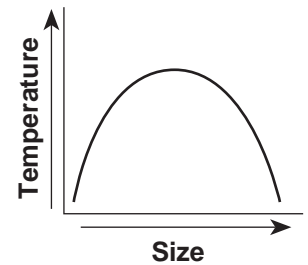

(4)

41 The diagram below represents the spectral lines from the light of an element in a laboratory on Earth.

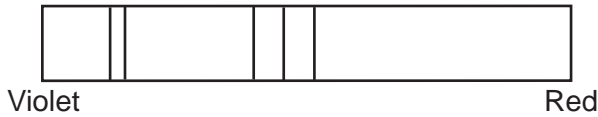

Which diagram below best represents the pattern of spectral lines from the same element when it was observed by Edwin Hubble in the light of one of the distant galaxies?

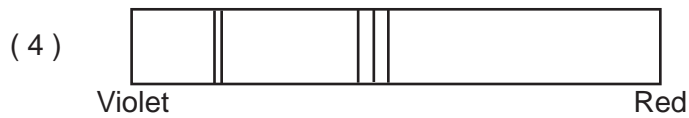
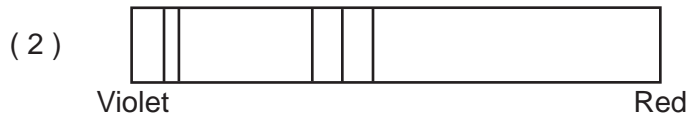

42 Cosmic microwave background radiation is classified as a form of electromagnetic energy because it

- (1) travels in waves through space
- (2) moves faster than the speed of light
- (3) is visible to humans
- (4) moves due to particle collisions



43 The current temperature indicated by the cosmic microwave background radiation is

- (1) higher than the temperature at which water boils
- (2) between the temperature at which water boils and room temperature
- (3) between room temperature and the temperature at which water freezes
- (4) lower than the temperature at which water freezes



Base your answers to questions 44 through 47 on the topographic map below and on your knowledge of Earth science. Points *A*, *B*, *C*, and *D* represent locations on the surface of Earth. Elevations are measured in feet.

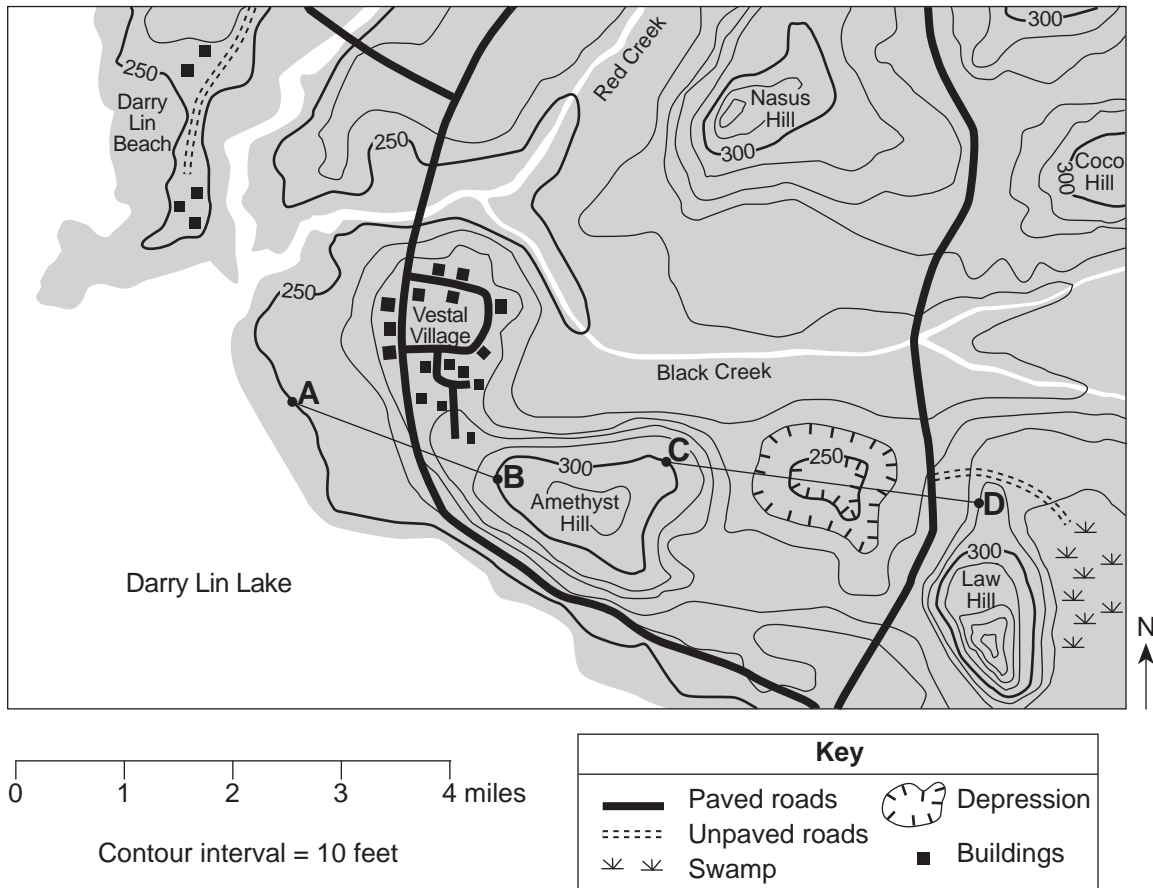

44 In which general direction does Red Creek flow?

- (1) northeast
- (2) southeast
- (3) southwest
- (4) northwest



45 What is the approximate gradient from point *A* to point *B* on the map?

- (1) 25 feet per mile
- (2) 50 feet per mile
- (3) 75 feet per mile
- (4) 100 feet per mile



46 What is a possible elevation for the surface of Darry Lin Lake?

- (1) 228 feet
- (2) 242 feet
- (3) 255 feet
- (4) 268 feet



47 Which cross section represents an accurate profile of the landscape between points *C* and *D*?

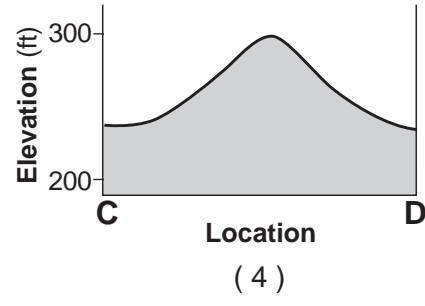
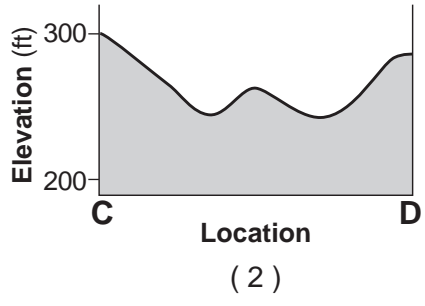
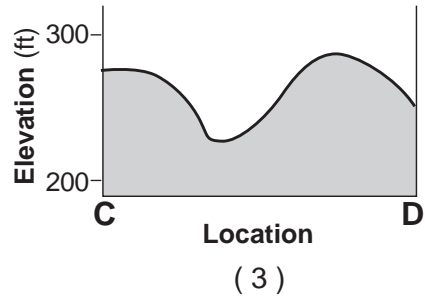
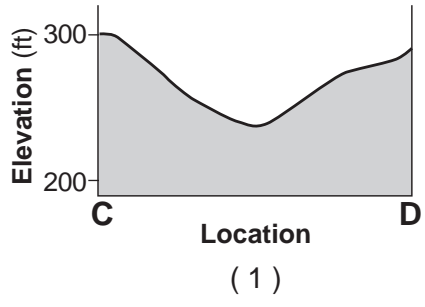

Base your answers to questions 48 through 50 on the geologic cross section and photograph below and on your knowledge of Earth science. The cross section represents the Palisades sill in southern New York State and the surrounding bedrock. Potassium-40 analysis determined the sill to be approximately 200,000,000 years old. The photograph shows a mastodont tooth found in glacial sediments nearby. Carbon-14 analysis determined this tooth to be approximately 11,400 years old.

Geologic Cross Section

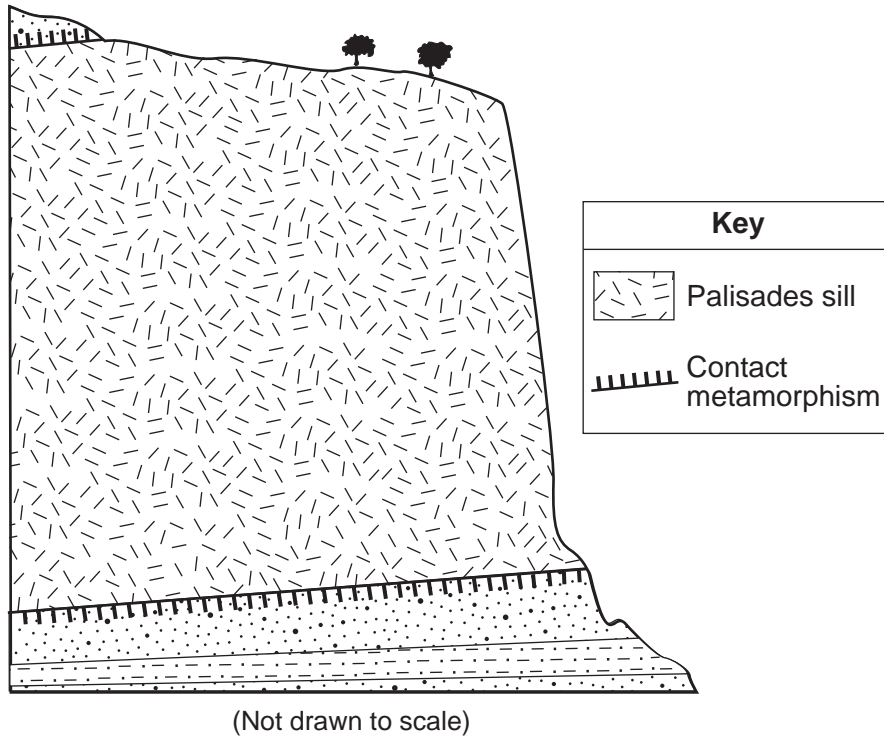

Mastodont Tooth



48 Which metamorphic rock was most likely produced in the contact zone between the Palisades sill and the sedimentary rock?

- (1) schist
- (2) slate
- (3) gneiss
- (4) quartzite

49 Potassium-40 is useful for radioactive dating of the Palisades sill because the half-life of potassium-40

- (1) decreased as the amounts of ^{40}Ar and ^{40}Ca in the sill increased
- (2) remained constant during the radioactive decay process
- (3) increased as pressure from the overlying sedimentary rock increased
- (4) was shortened by the high temperature of the magma that formed the sill

50 The mastodont tooth and the entire Palisades sill represented above are similar in that both

- (1) can be found in deposits left by the last continental ice sheet in New York State
- (2) are fossils of animals that once lived in New York State
- (3) can be used as time markers to date nearby geologic events
- (4) are Mesozoic in age

Part B-2

Answer all questions in this part.

Directions (51–65): Record your answers in the spaces provided in your answer booklet. Some questions may require the use of the *2011 Edition Reference Tables for Physical Setting/Earth Science*.

Base your answers to questions 51 through 54 on the diagram below and on your knowledge of Earth science. The diagram represents a portion of a stream and its surrounding bedrock. The arrows represent the movement of water molecules by the processes of the water cycle. The water table is indicated by a dashed line. Letter *A* represents a water cycle process occurring at a specific location. Letter *d* represents the distance between the water table and the land surface.

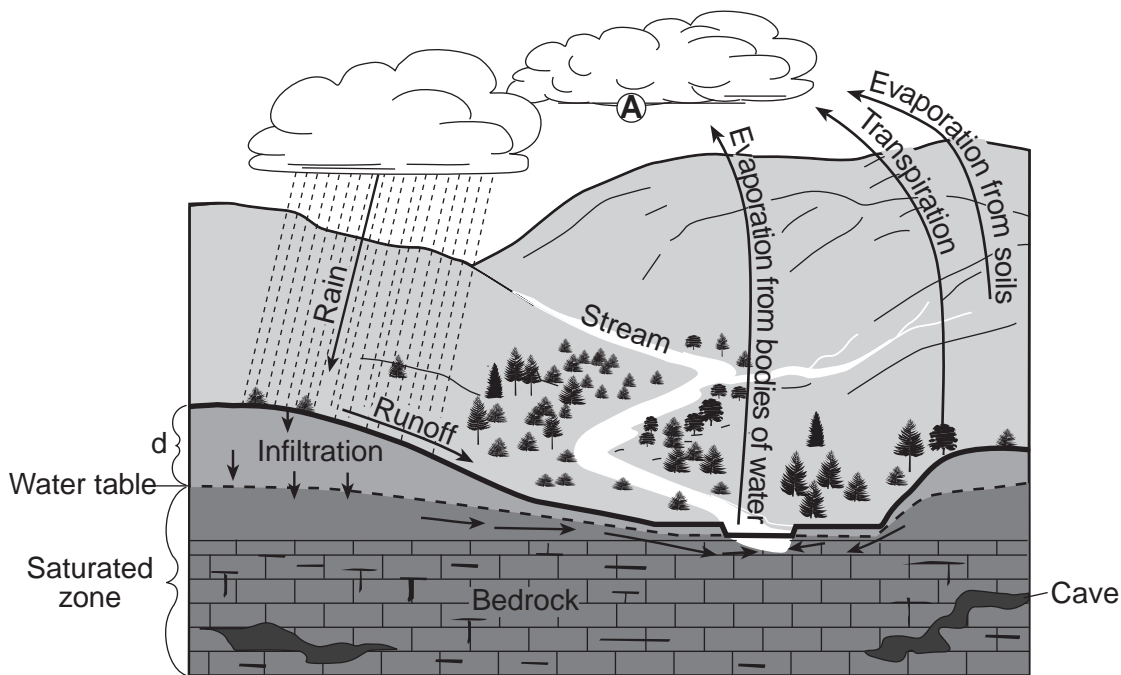

51 Identify water cycle process A, which produces cloud droplets. [1]



52 Describe the soil permeability and the land surface slope that allow the most infiltration of rainwater and the *least* runoff. [1]



53 Slightly acidic groundwater has been seeping through cracks and openings in the limestone bedrock of this area, producing caves. State whether the type of weathering that produces these caves is mainly chemical or physical, and identify *one* characteristic of limestone that allows this type of weathering to occur. [1]



54 Explain why the distance, *d*, from the water table to the land surface would *decrease* after several days of heavy rainfall. [1]



Base your answers to questions 55 through 59 on the diagram below and on your knowledge of Earth science. The diagram represents the Moon at eight numbered positions in its orbit around Earth. The nighttime sides of the Moon and Earth are shaded.

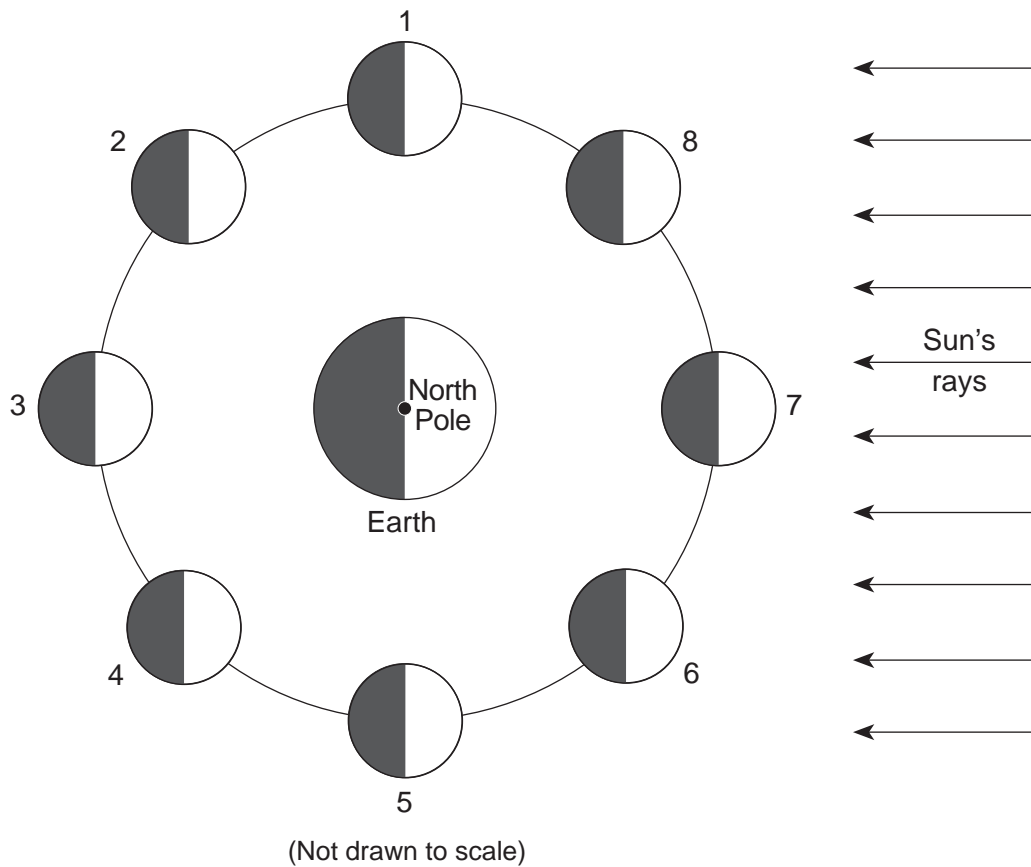

55 The photograph below shows a phase of the Moon as observed from New York State.



State the numbered position at which the Moon was located when the photograph was taken. [1]

56 State the number of days the Moon takes to go through one complete cycle of Moon phases from full Moon to full Moon as viewed from Earth. [1]



57 State the numbered position of the Moon that could result in a lunar eclipse. [1]



58 Explain why the Moon's orbital velocity is slowest when the Moon is farthest from Earth. [1]



59 Explain how the Moon's rotation and revolution cause the same side of the Moon to always face Earth. [1]



Base your answers to questions 60 and 61 on the partial geologic map in your answer booklet and on your knowledge of Earth science. The map shows the geographical distribution of most of the Devonian-age surface bedrock in New York State.

60 On the map *in your answer booklet*, place an **X** at a location where the gastropod fossil *Platyceras* might be found in the surface bedrock. [1]

61 State the name of the New York State landscape region that includes most of the Devonian-age surface bedrock shown on the map. [1]

Base your answers to questions 62 through 65 on the map below and on your knowledge of Earth science. The map shows the location of Sandy Creek, west of Rochester, New York. X and Y represent points on the banks of the stream.

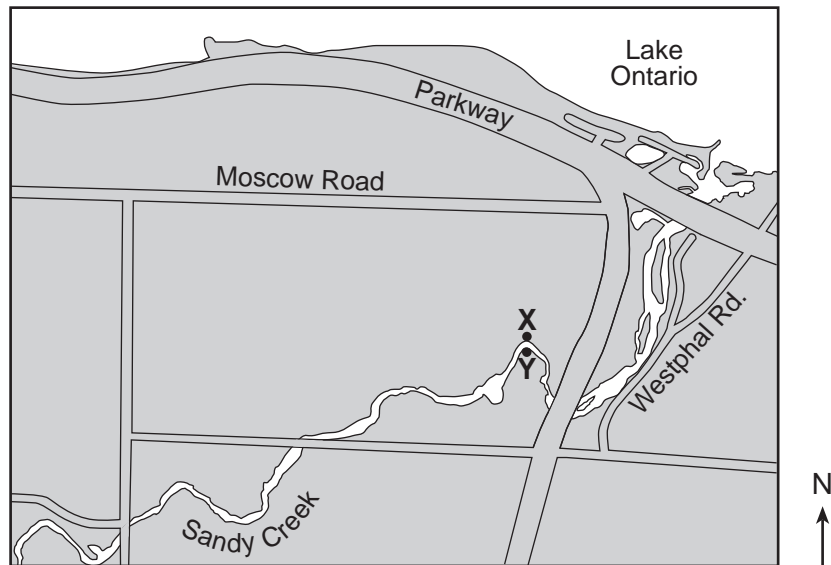

62 *In your answer booklet*, draw a line to represent the shape of the stream bottom from point X to point Y. [1]

63 Explain why sediments are deposited when Sandy Creek enters Lake Ontario. [1]

64 The symbols representing four sediment particles are shown in the key in your answer booklet. These particles are being transported by Sandy Creek into Lake Ontario. On the cross section *in your answer booklet*, draw the symbols on the bottom of Lake Ontario to show the relative position where *each* sediment particle is most likely deposited. [1]

65 Record the minimum velocity this stream needs to transport a 2.0-cm-diameter particle. [1]

Part C

Answer all questions in this part.

Directions (66–85): Record your answers in the spaces provided in your answer booklet. Some questions may require the use of the *2011 Edition Reference Tables for Physical Setting/Earth Science*.

Base your answers to questions 66 through 68 on the table and photograph below and on your knowledge of Earth science. The table shows the approximate mineral percent composition of an igneous rock. The photograph shows the true-scale crystal sizes in this igneous rock.

Mineral Name	Percentage of Mineral Present
plagioclase feldspar	55%
biotite	15%
amphibole	30%



0 1
centimeter

66 Identify *two* elements that are commonly found in all three minerals in the data table. [1]



67 Identify this igneous rock. [1]



68 Identify *two* processes that formed this rock. [1]



Base your answers to questions 69 through 73 on the map below and on your knowledge of Earth science. The map shows the major islands in the Galapagos Island chain. These islands were formed by volcanic eruptions as the tectonic plate passed over the Galapagos Hot Spot. The age of the volcanic bedrock on certain islands is shown in millions of years (my).

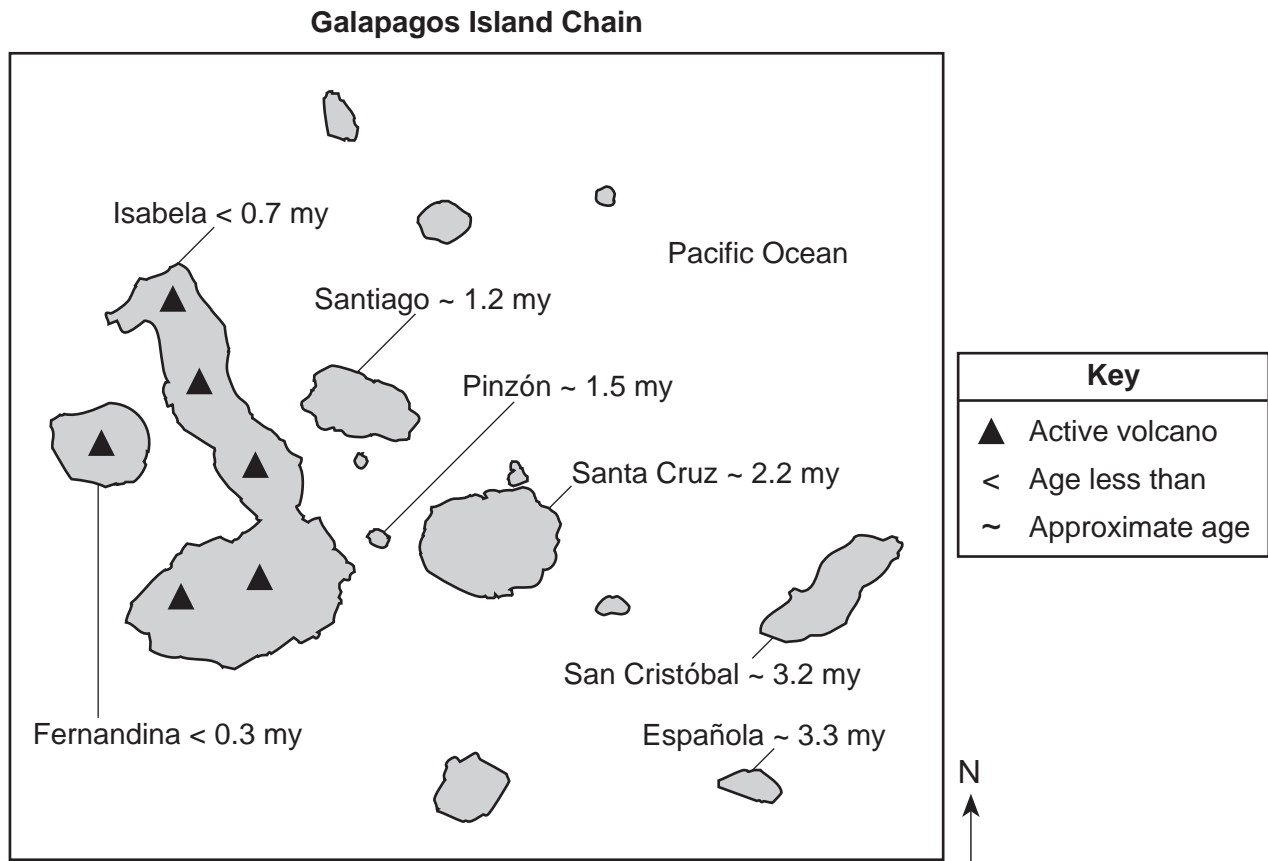

69 During what geologic epoch did the bedrock on the island of San Cristóbal form? [1]



70 Based on the age of the bedrock of the Galapagos Islands, in which direction does the tectonic plate containing the islands appear to be moving away from the Galapagos Hot Spot? [1]



71 The Galapagos Hot Spot is located closest to what type of tectonic plate boundary? [1]



72 Describe what caused a vesicular texture in some of the volcanic rocks that formed when lava cooled on these islands. [1]

73 Some of the magma at the Galapagos Hot Spot is believed to originate 1000 kilometers below Earth's surface. What is the approximate temperature of Earth's interior at that depth? [1]



Base your answers to questions 74 through 76 on the data table below and on your knowledge of Earth science. The table shows the area, in million square kilometers, of the Arctic Ocean covered by ice from June through November. The average area covered by ice from 1979 to 2000 from June to November is compared to the area covered by ice in 2005 for the same time period.

Data Table

Month	Average Area Covered by Ice 1979–2000 (million km²)	Area Covered by Ice 2005 (million km²)
June	12.2	11.3
July	10.1	8.9
August	7.7	6.3
September	7.0	5.6
October	9.3	8.5
November	11.3	10.5

74 Use the information in the data table to construct a line graph. On the grid *in your answer booklet*, plot the data for the area covered by ice in 2005 for *each* month shown on the data table and connect the plots with a line. The average area covered by ice for 1979–2000 has been plotted and labeled on the grid. [1]

75 Scientists have noted that since 2002, the area of the Arctic Ocean covered by ice during these warmer months has shown an overall decrease from the long-term average (1979–2000). State *one* way in which this ice coverage since 2002 and the ice coverage shown in the 2005 data above provide evidence of global warming, when compared to this long-term average. [1]

76 Identify *one* greenhouse gas that is believed to cause global warming. [1]



Base your answers to questions 77 through 79 on the topographic map of Hawaii in your answer booklet and on your knowledge of Earth science. Points *A* and *B* represent surface locations on the island. Land elevations and Pacific Ocean depths are shown in meters.

77 On the map *in your answer booklet*, draw the -1000 -meter ocean-depth isoline. Extend the isoline to the edge of the map. [1]

78 The average annual air temperature at location *A* is approximately 77°F , while the average annual air temperature at location *B* is approximately 55°F . Explain why location *B* has cooler average temperatures. [1]

79 The map below shows the locations of three volcanoes on the island of Hawaii. The arrows represent the direction of the planetary winds. Points *X* and *Y* represent surface locations on the island.

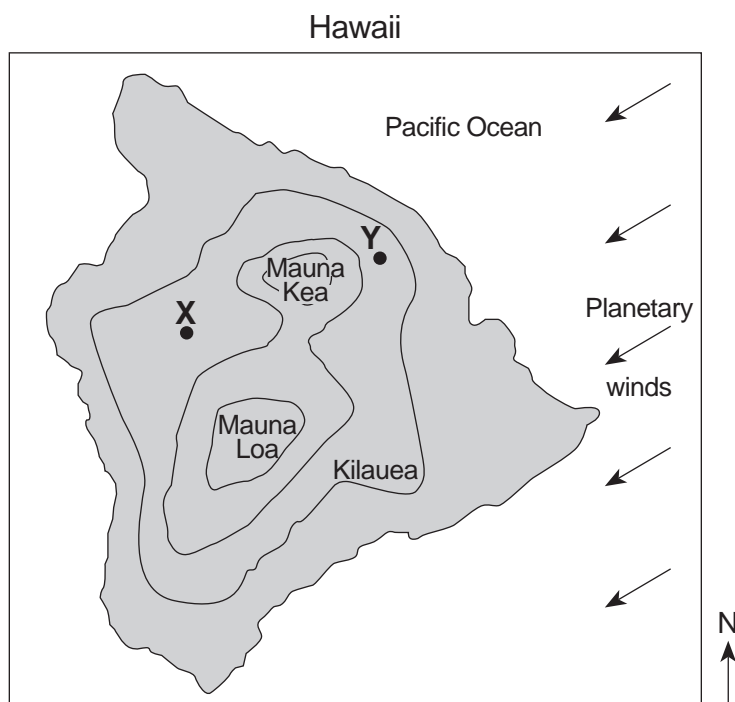

Explain why location *X* usually receives *less* annual precipitation than location *Y*. [1]

Base your answers to questions 80 through 82 on the diagram in your answer booklet and on your knowledge of Earth science. The diagram represents the Sun's apparent path on the equinoxes and the longest and shortest days of the year for a location in New York State. Points X, Y, and Z represent the solar noon positions along daily Sun paths X, Y, and Z.

80 On the diagram *in your answer booklet*, draw *one* arrow in *each* box on path Z to indicate the Sun's apparent direction of movement along path Z. [1]



81 State *one* possible date of the year represented by *each* apparent path of the Sun. [1]



82 State the rate, in degrees per hour, that the Sun appears to travel along path X from sunrise to sunset. [1]



Base your answers to questions 83 through 85 on the cross section in your answer booklet and on your knowledge of Earth science. The cross section represents several geologic structures. Line AB represents a fault. C and D represent rock units.

83 On the cross section *in your answer booklet*, place an **X** on the unconformity. [1]



84 On the cross section *in your answer booklet*, place *two* arrows, *one* on *each* side of fault AB, to show the relative movement of the rock units on each side of the fault. [1]



85 Indicate the proper sequence of the geologic events listed *in your answer booklet* by writing the number 1 after the first event, the number 2 after the second event, and the number 3 after the last event. [1]



FOR TEACHERS ONLY

The University of the State of New York
REGENTS HIGH SCHOOL EXAMINATION

PS-ES PHYSICAL SETTING/EARTH SCIENCE

Friday, June 14, 2013 — 9:15 a.m. to 12:15 p.m., only

SCORING KEY AND RATING GUIDE

Directions to the Teacher:

Refer to the directions on page 2 before rating student papers.

Updated information regarding the rating of this examination may be posted on the New York State Education Department's web site during the rating period. Check this web site at: <http://www.p12.nysed.gov/assessment/> and select the link "Scoring Information" for any recently posted information regarding this examination. This site should be checked before the rating process for this examination begins and several times throughout the Regents Examination period.

Part A and Part B-1

Allow 1 credit for each correct response.

Part A

1 4	10 4	19 2	28 1
2 3	11 1	20 3	29 2
3 2	12 1	21 3	30 4
4 3	13 2	22 2	31 4
5 1	14 1	23 2	32 2
6 2	15 2	24 3	33 4
7 4	16 4	25 4	34 4
8 3	17 1	26 3	35 1
9 1	18 1	27 4	

Part B-1

36 4	40 2	44 3	48 4
37 4	41 3	45 1	49 2
38 2	42 1	46 2	50 3
39 4	43 4	47 1	

Directions to the Teacher

Follow the procedures below for scoring student answer papers for the Regents Examination in Physical Setting/Earth Science. Additional information about scoring is provided in the publication *Information Booklet for Scoring Regents Examinations in the Sciences*.

Do not attempt to correct the student's work by making insertions or changes of any kind. If the student's responses for the multiple-choice questions are being hand scored prior to being scanned, the scorer must be careful not to make any marks on the answer sheet except to record the scores in the designated score boxes. Marks elsewhere on the answer sheet will interfere with the accuracy of the scanning.

Allow 1 credit for each correct response.

At least two science teachers must participate in the scoring of the Part B–2 and Part C open-ended questions on a student's paper. Each of these teachers should be responsible for scoring a selected number of the open-ended questions on each answer paper. No one teacher is to score more than approximately one-half of the open-ended questions on a student's answer paper. Teachers may not score their own students' answer papers.

Students' responses must be scored strictly according to the Scoring Key and Rating Guide. For open-ended questions, credit may be allowed for responses other than those given in the rating guide if the response is a scientifically accurate answer to the question and demonstrates adequate knowledge as indicated by the examples in the rating guide. On the student's separate answer sheet, for each question, record the number of credits earned and the teacher's assigned rater/scorer letter.

Fractional credit is *not* allowed. Only whole-number credit may be given for a response. If the student gives more than one answer to a question, only the first answer should be rated. Units need not be given when the wording of the questions allows such omissions.

For hand scoring, raters should enter the scores earned in the appropriate boxes printed on the separate answer sheet. Next, the rater should add these scores and enter the total in the space provided. The student's score for the Earth Science Performance Test should be recorded in the space provided. Then the student's raw scores on the written test and the performance test should be converted to a scale score by using the conversion chart that will be posted on the Department's web site at: <http://www.p12.nysed.gov/assessment/> on Friday, June 14, 2013. The student's scale score should be entered in the box labeled "Scale Score" on the student's answer sheet. The scale score is the student's final examination score.

Schools are not permitted to rescore any of the open-ended questions on this exam after each question has been rated once, regardless of the final exam score. Schools are required to ensure that the raw scores have been added correctly and that the resulting scale score has been determined accurately.

Because scale scores corresponding to raw scores in the conversion chart may change from one administration to another, it is crucial that, for each administration, the conversion chart provided for that administration be used to determine the student's final score.

Part B–2

Allow a maximum of 15 credits for this part.

51 [1] Allow 1 credit for condensation.

52 [1] Allow 1 credit if *both* the soil permeability and the land surface slope are correct. Acceptable responses include, but are not limited to:

Soil permeability:

- high
- The soil is unsaturated.
- a soil that allows water to easily or rapidly seep through
- The surface of the soil is not frozen.
- a very permeable soil
- loosely packed large particles

Land surface slope:

- a gentle slope
- a slope that is not steep
- a level slope
- flat/a flat plain

53 [1] Allow 1 credit for chemical weathering and an acceptable characteristic of limestone. Acceptable characteristics include, but are not limited to:

- Acid dissolves limestone.
- The calcite in the limestone chemically reacts with acid.
- Limestone is composed of calcite.

54 [1] Allow 1 credit. Acceptable responses include, but are not limited to:

- The heavy rainfall will infiltrate the ground, causing the water table to rise closer to the surface.
- Infiltration will occur.
- The ground becomes more saturated.
- The saturated zone will increase.
- The water table will rise.
- erosion of the land surface

Note: Do *not* allow credit for the process of weathering acting alone.

55 [1] Allow 1 credit for position number 1.

56 [1] Allow 1 credit for any value from 29 d to 30 d.

57 [1] Allow 1 credit for position number 3.

58 [1] Allow 1 credit. Acceptable responses include, but are not limited to:

- The gravitational attraction between the Moon and Earth is least when they are farthest apart.
- The force of gravity is less.
- Gravitational attraction is greater when the Moon is closer to Earth.

59 [1] Allow 1 credit. Acceptable responses include, but are not limited to:

- The Moon's period of rotation and period of revolution are equal.
- The Moon rotates only once per revolution.
- The Moon rotates and revolves once in 27.3 days.
- The Moon rotates and revolves at the same rate.

60 [1] Allow 1 credit if the center of the **X** is within the Middle Devonian zone *or* the Early and Middle Devonian zone located northwest of New York City.

61 [1] Allow 1 credit. Acceptable responses include, but are not limited to:

- Allegheny Plateau
- Appalachian Plateau
- Appalachian Uplands

60

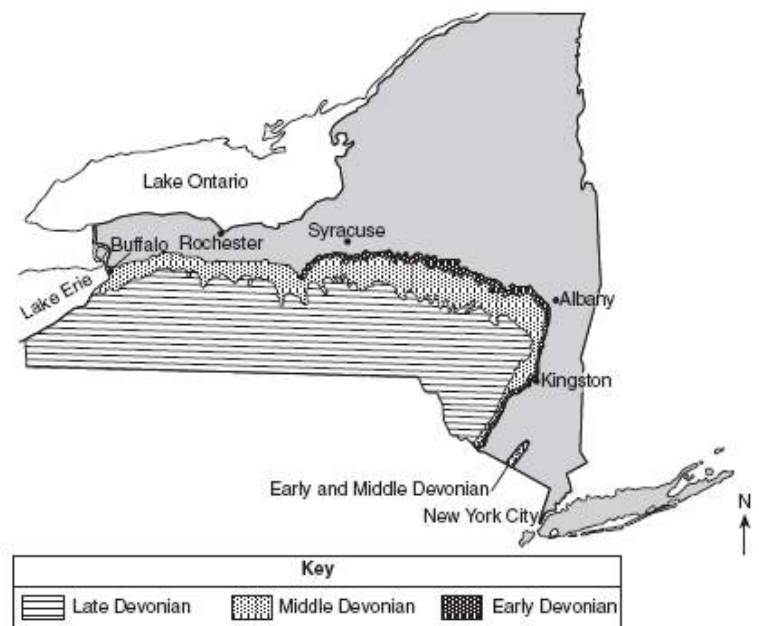

62 [1] Allow 1 credit for a streambed that is deeper near the X.

Example of a 1-credit response:

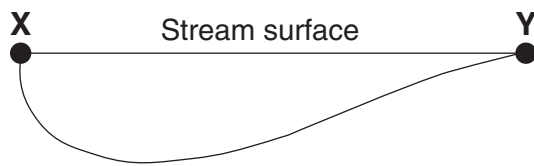

63 [1] Allow 1 credit. Acceptable responses include, but are not limited to:

- Water velocity decreases, causing some sediment to be dropped.
- The stream slows down as it enters the lake.

64 [1] Allow 1 credit if the relative positions of the symbols or particle names are in the order shown.

Example of a 1-credit response:

Key	
□	Small pebble
△	Sand
○	Silt
×	Clay

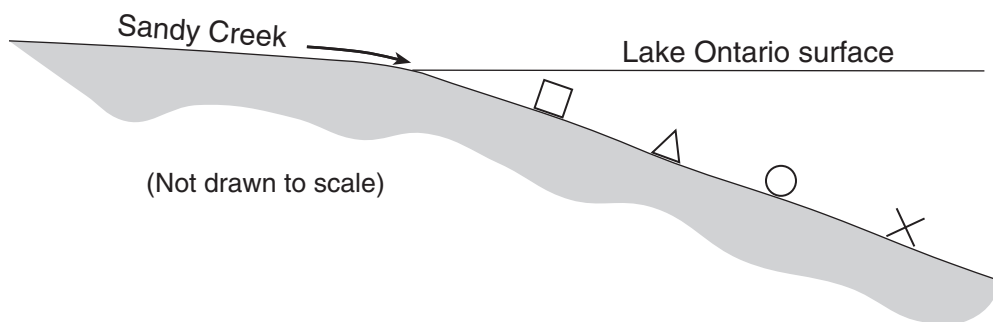

65 [1] Allow 1 credit for any value from 80 cm/s to 100 cm/s.

Part C

Allow a maximum of 20 credits for this part.

- 66** [1] Allow 1 credit for *two* of the three correct responses below.
- silicon *or* Si
 - oxygen *or* O
 - aluminum *or* Al
- 67** [1] Allow 1 credit for diorite.
- 68** [1] Allow 1 credit for *two* correct responses. Acceptable responses include, but are not limited to:
- melting
 - cooling
 - solidification/crystallization/hardening
 - heating
- 69** [1] Allow 1 credit for Pliocene Epoch.
- 70** [1] Allow 1 credit. Acceptable responses include, but are not limited to:
- southeastward
 - south
 - ESE
 - east
 - SSE
 - to the right
- 71** [1] Allow 1 credit. Acceptable responses include, but are not limited to:
- divergent
 - transform
 - mid-ocean ridge
- 72** [1] Allow 1 credit. Acceptable responses include, but are not limited to:
- Dissolved gases are released from lava as a result of a decrease in pressure.
 - gas/air bubbles trapped in rapidly cooling lava
 - There was an explosive eruption of a volcano.
- 73** [1] Allow 1 credit for any value from 3100°C to 3300°C.

- 74 [1] Allow 1 credit if the centers of *all six* plots are within the circles shown and are correctly connected with a line that passes within each circle.

Note: It is recommended that an overlay of the same scale as the student answer booklet be used to ensure reliability in rating.

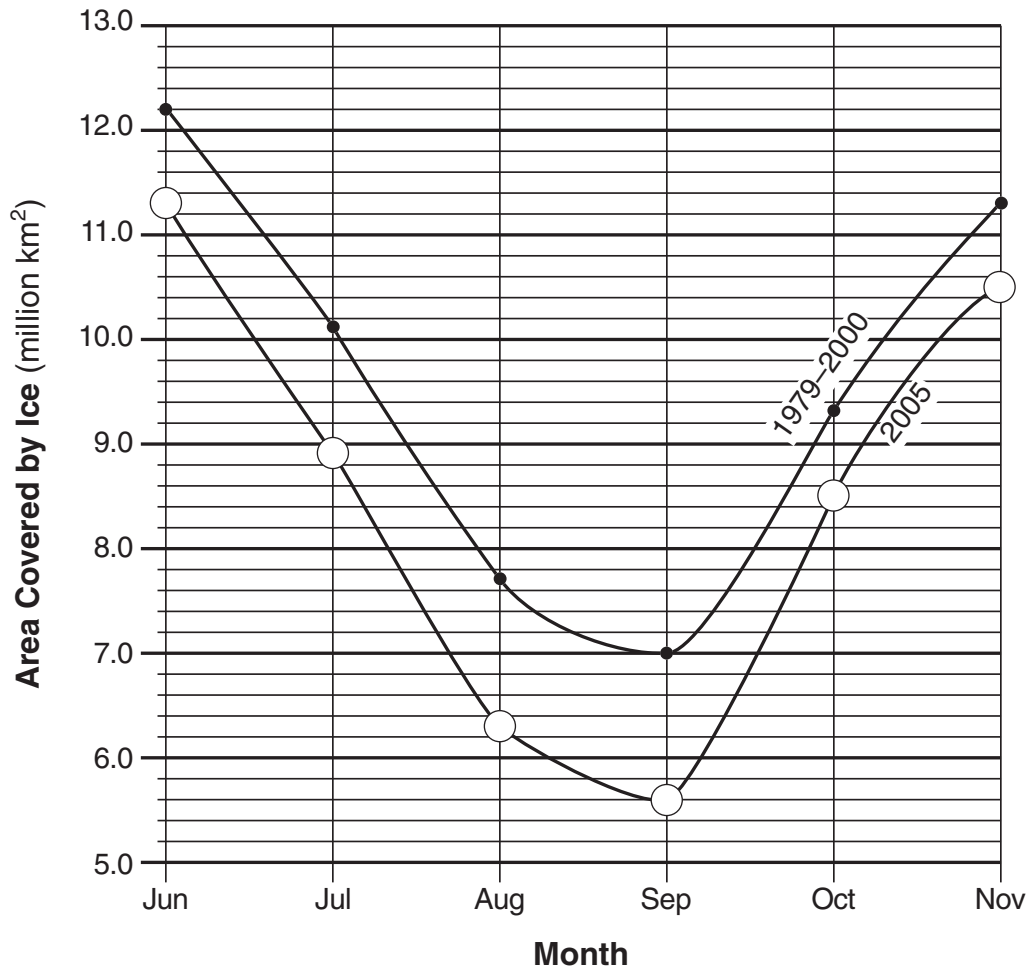

- 75 [1] Allow 1 credit. Acceptable responses include, but are not limited to:
- The area covered by ice in 2005 was less than the average area covered by ice from 1979 to 2000.
 - The area covered by ice was less, showing evidence of global warming.
 - More ice melted in 2005 than the average that melted from 1979 to 2000.
 - The ice caps were melting, causing less surface ice in 2005.
 - There was less ice in 2005.

- 76 [1] Allow 1 credit. Acceptable responses include, but are not limited to:
- carbon dioxide *or* CO_2
 - methane *or* CH_4
 - water vapor *or* H_2O gas
 - nitrous oxide *or* N_2O
 - ozone *or* O_3
 - chlorofluorocarbons *or* CFCs

77 [1] Allow 1 credit if the -1000 isoline is correctly drawn to the edge of the map. If additional isolines are drawn, all isolines must be correct to receive credit.

Example of a 1-credit response:

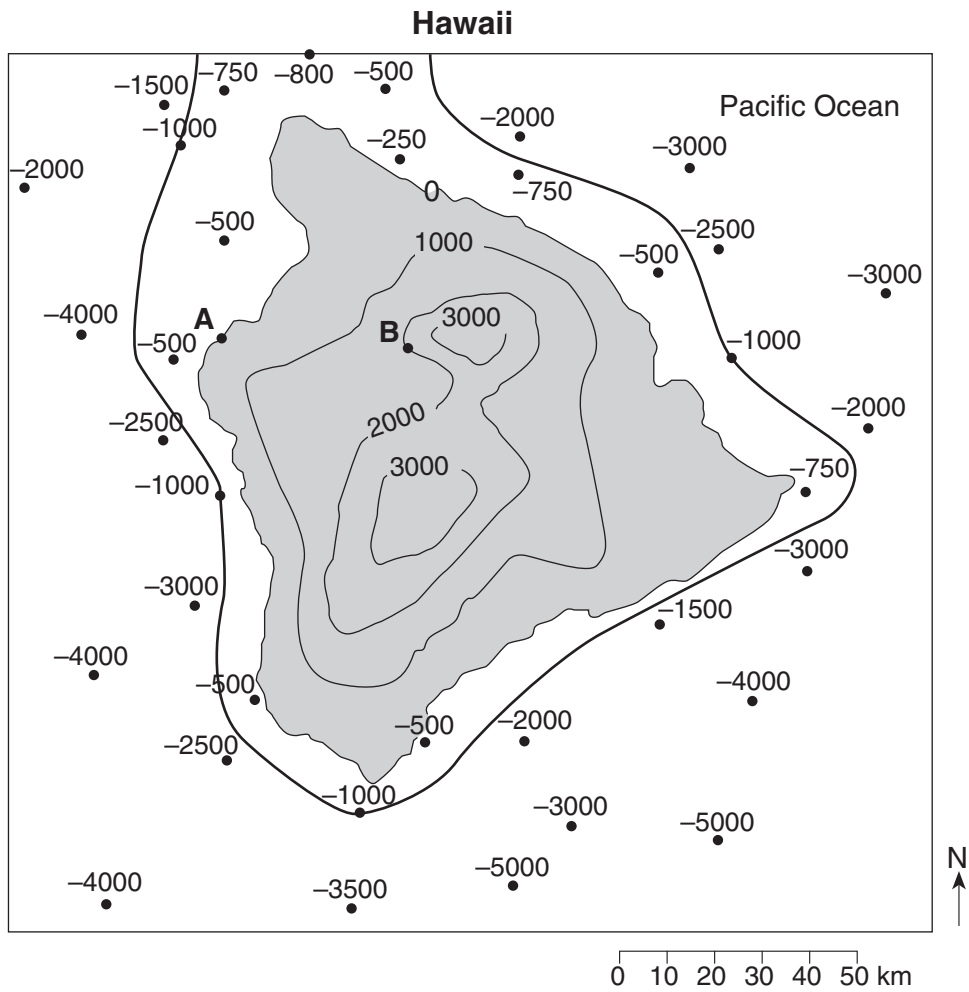

78 [1] Allow 1 credit. Acceptable responses include, but are not limited to:

- *B* is higher in elevation.
- Higher elevations have cooler temperatures.
- *B* is in the mountains.

79 [1] Allow 1 credit. Acceptable responses include, but are not limited to:

- Location *X* is located on the leeward side of a mountain.
- Location *X* is located on the rain shadow side of a mountain.
- Location *Y* is located on the windward side of a mountain.
- Moist air rises over location *Y*, resulting in precipitation.
- orographic effect
- A mountain/volcano barrier separates *X* and *Y*.
- Planetary winds bring moisture to location *Y*, but lack this moisture by the time they get to location *X*.
- Location *X* is farther from the ocean.

80 [1] Allow 1 credit if *both* arrows are correctly drawn.

Example of a 1-credit response:

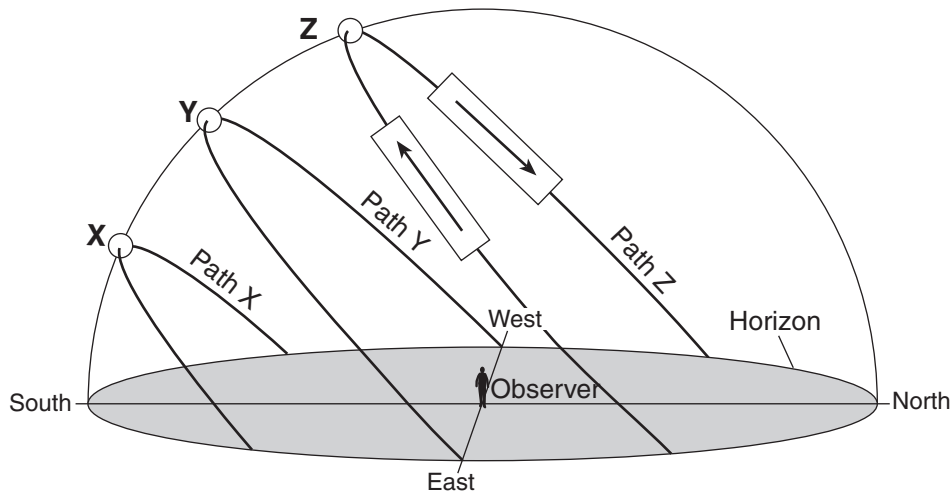

81 [1] Allow 1 credit if *all three* responses are correct. Acceptable responses include, but are not limited to:

Path X:

- Dec. 20 *or* Dec. 21 *or* Dec. 22
- winter solstice
- first day of winter

Path Y:

- March 20 *or* March 21 *or* March 22
- Sept. 21 *or* Sept. 22 *or* Sept. 23
- autumnal equinox *or* fall equinox
- vernal equinox *or* spring equinox
- an equinox
- first day of spring *or* first day of fall

Path Z:

- June 20 *or* June 21 *or* June 22
- summer solstice
- first day of summer

82 [1] Allow 1 credit for $15^\circ/\text{h}$.

83 [1] Allow 1 credit if the center of the **X** is placed on or near the unconformity (wavy line) within the region indicated in the diagram below.

Note: Allow credit if a symbol other than an **X** is used.
It is recommended that an overlay of the same scale as the student answer booklet be used to ensure reliability in rating.

84 [1] Allow 1 credit for the correct placement of *both* arrows as shown below.

Example of a 2-credit response for questions 83 and 84:

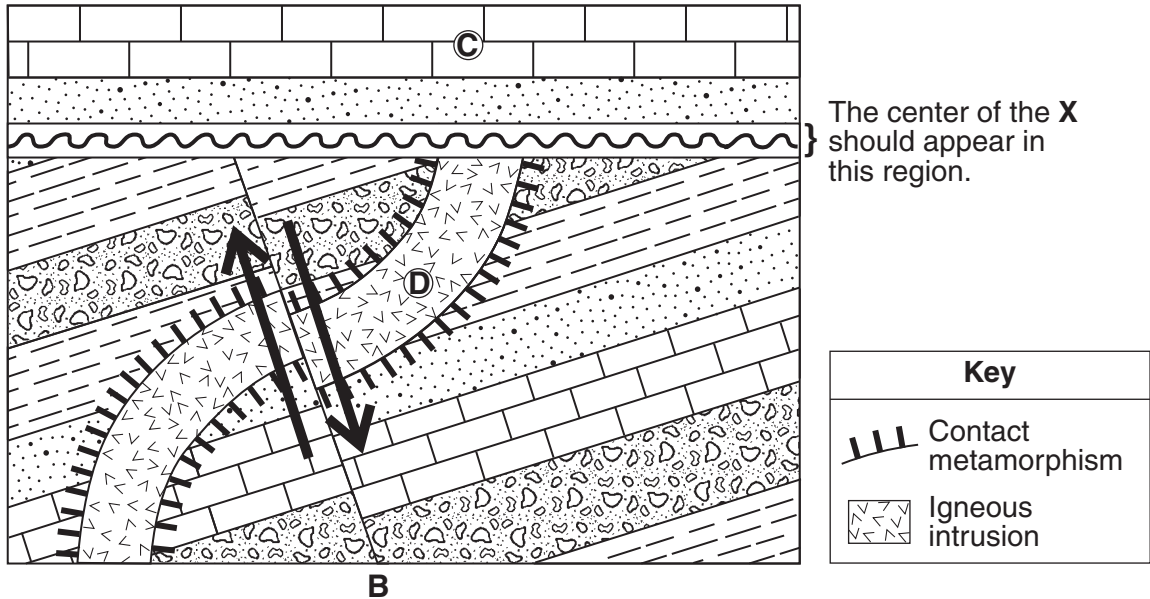

85 [1] Allow 1 credit for a correct response as shown below:

Deposition of rock unit C: 3

Intrusion of rock unit D: 1

Faulting along line AB: 2